



HOME
DECORATORS
COLLECTION

Assembled Semi-
Custom

ONLINE PERSONAL DESIGN PACKET



- All Plywood Cabinets
- Ships in 7-10 Days
- Limited Lifetime Warranty
- Factory Built to Order



Newport Pacific White

hdckitchens.com

ONLINE PERSONAL DESIGNER

Anabel

designservices@hdckitchens.com

Phone 866.373.9131 x1222

PREPARED FOR

Leavitt, Michael

Kitchen

9/29/20



Purchaser/Homeowner must Verify prior to purchase:

All wall lengths, ceiling and wall heights (including soffits or bulkheads)

All window and door sizes and exact locations

Any floor or ceiling obstacles that interfere with the design

Appliance, sink sizes and flooring footprint locations if applicable

All plumbing, electrical and/or gas are in the correct location on this design OR that they can be relocated.

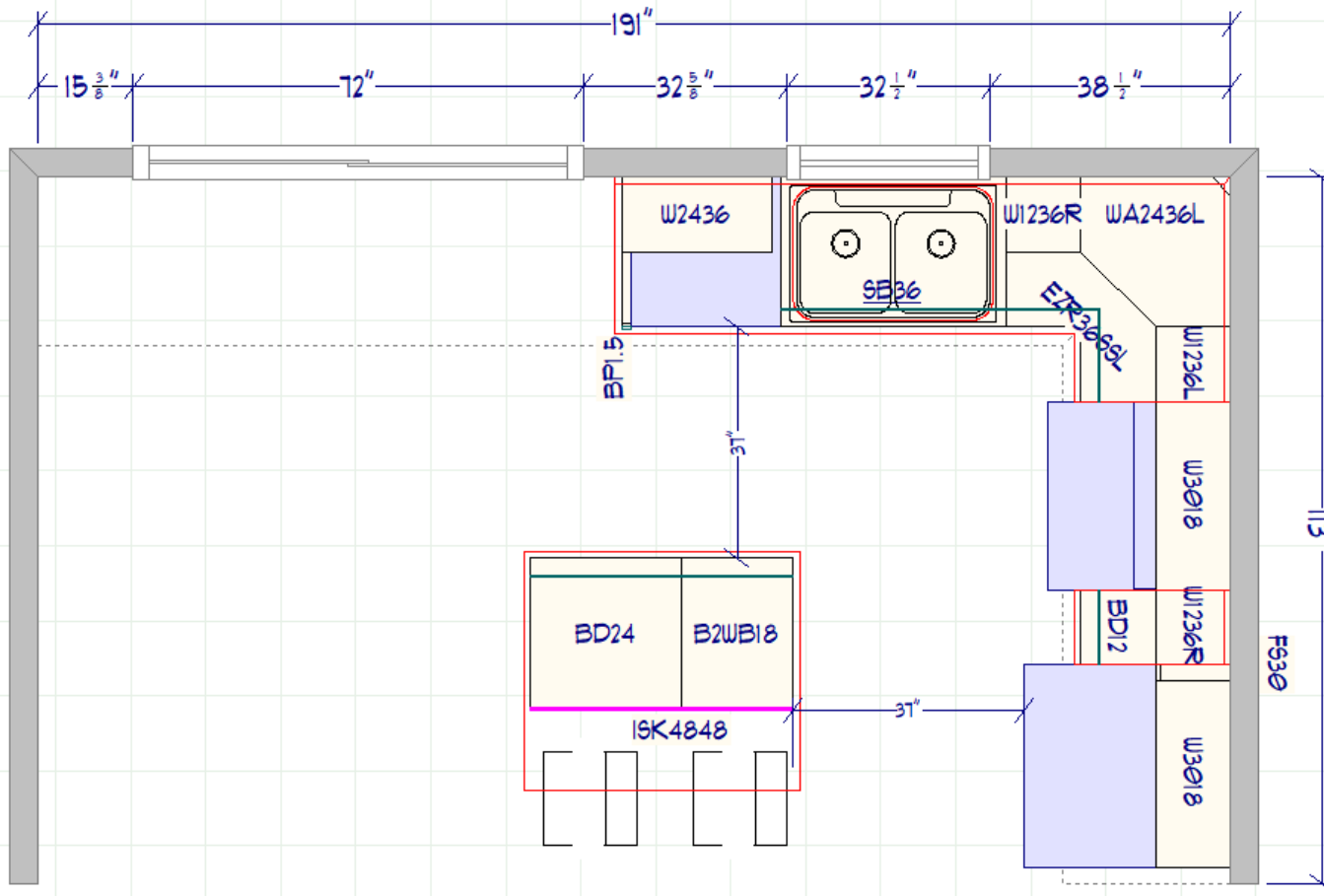

NOTE TO CUSTOMER: Please verify all dimensions for accuracy. Contact your personal designer with any changes to your layout at designservices@hdckitchens.com.



NOTE TO CUSTOMER: Please verify all dimensions for accuracy. Contact your personal designer with any changes to your layout at designservices@hdckitchens.com.



NOTE TO CUSTOMER: Please verify all dimensions for accuracy. Contact your personal designer with any changes to your layout at designservices@hdckitchens.com.



NOTE TO CUSTOMER: Please verify all dimensions for accuracy. Contact your personal designer with any changes to your layout at designservices@hdckitchens.com.

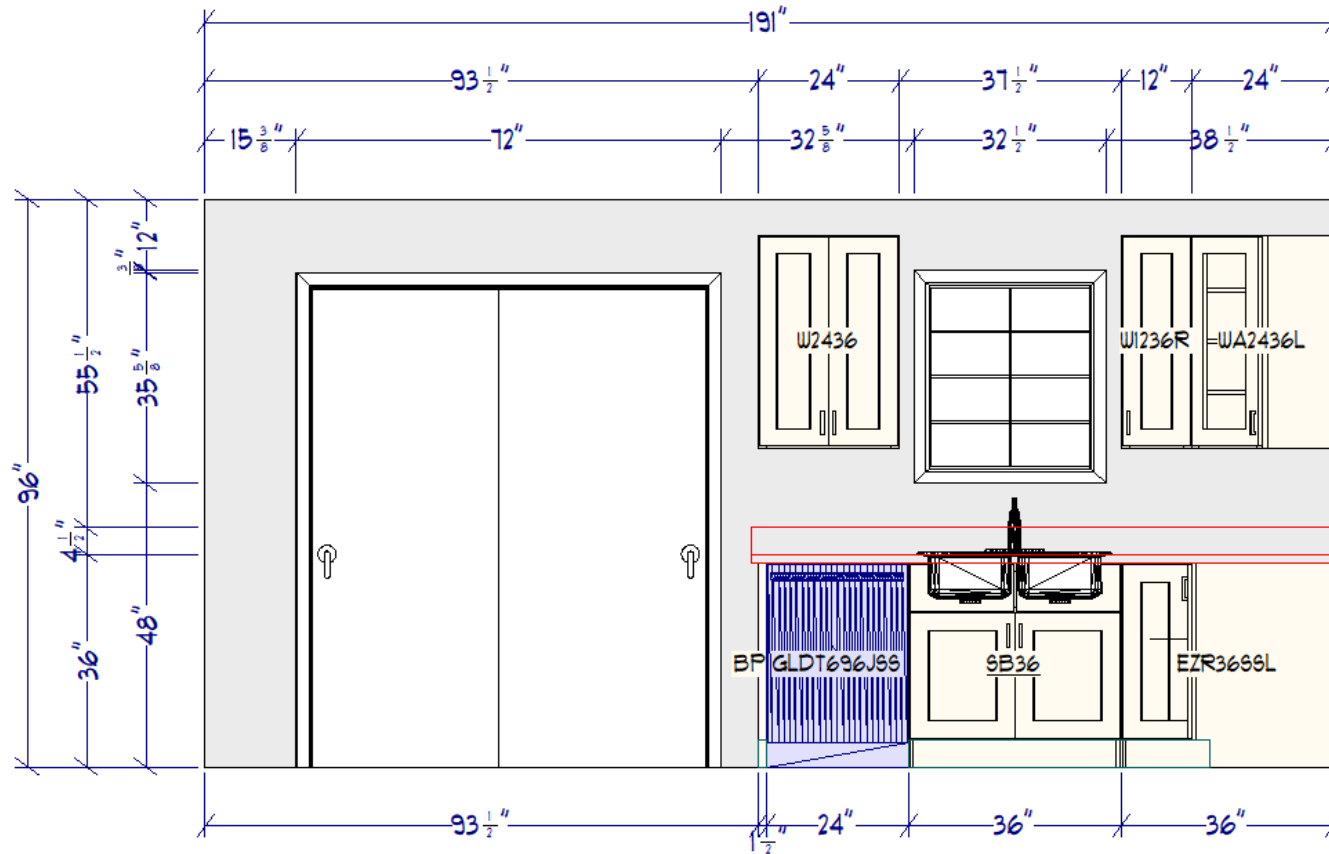

NOTE TO CUSTOMER: Please verify all dimensions for accuracy. Contact your personal designer with any changes to your layout at designservices@hdckitchens.com.

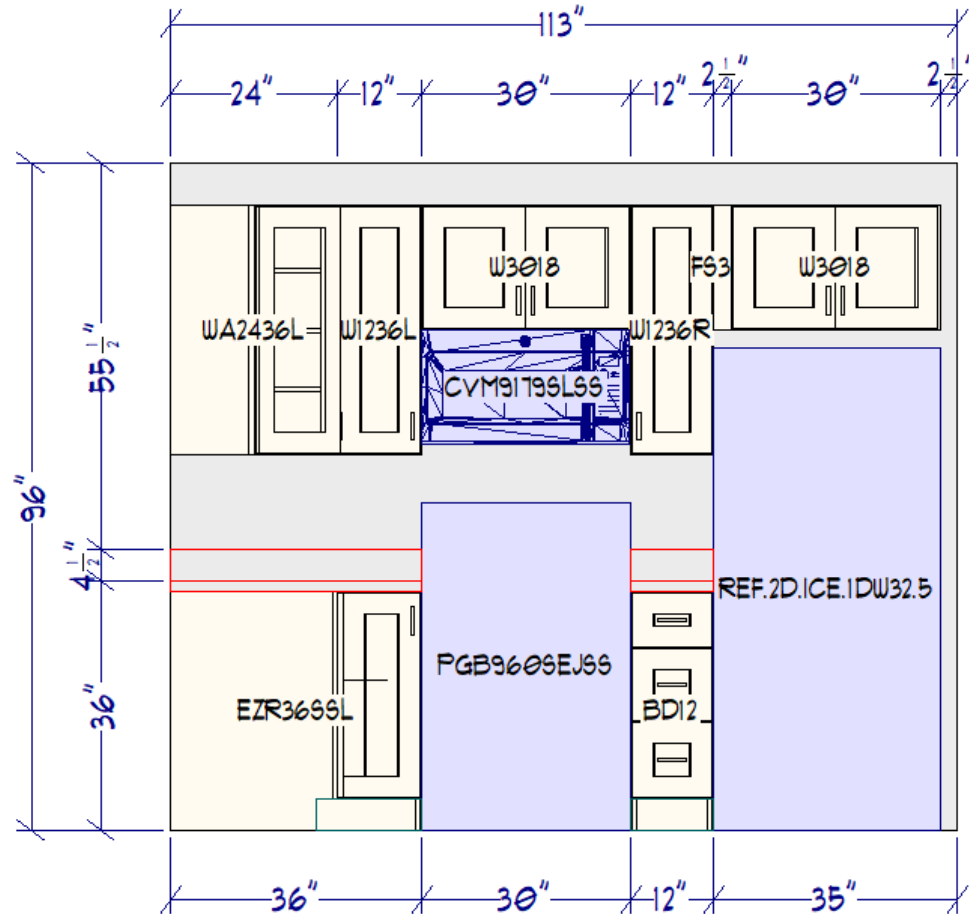

NOTE TO CUSTOMER: Please verify all dimensions for accuracy. Contact your personal designer with any changes to your layout at designservices@hdckitchens.com.

YOUR DOOR STYLE SELECTION:



Newport Pacific White (NPW)



- 3/4" thick solid MDF 3" wide Shaker frame wall and base doors with 5/8" thick solid MDF recessed center panels
- 3/4" thick solid MDF 3" wide Shaker frame drawer fronts with 5/8" thick solid MDF recessed center panels
- Fully concealed hinges
- Available in Polar White painted finish
- Decorative hardware required

...goes great with*

DH45-100



- Euro railing pull
- Brushed nickel
- 3-3/4" center
- 7" outside length

DH99-128



- Contemporary bow pull
- Brushed nickel
- 3-3/4" center
- 5-1/2" outside length

***DECORATIVE HARDWARE** is not included in your quote. Ask your designer for details!

NOTE TO CUSTOMER: Please verify all dimensions for accuracy. Contact your personal designer with any changes to your layout at designservices@hdckitchens.com.

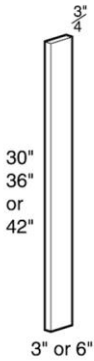

30"
36"
or
42"

3"
or
6"

$\frac{3}{4}$ "

$\frac{3}{4}$ " thick solid wood

Face and all edges finished



Fillers are used to cover the space between a wall and cabinetry to allow doors and drawers to open without binding. They may also be used between cabinetry to act as a spacer or as specified by your designer.

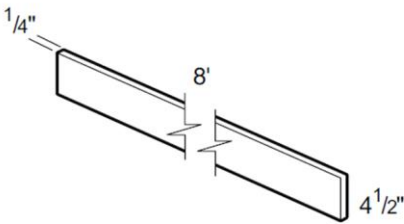

$\frac{1}{4}$ "

8'

$4\frac{1}{2}$ "

$\frac{1}{4}$ " Thick solid wood veneer or white vinyl
Finished front side only



Matching Toe Kick 8' (MTK8) is used to cover the unfinished toe space of base cabinetry, and to help hide any gaps between cabinetry and cover field-constructed cabinet platforms.

NOTE TO CUSTOMER: Please verify all dimensions for accuracy. Contact your personal designer with any changes to your layout at designservices@hdckitchens.com.

PLEASE VERIFY ALL ITEMS BELOW:

All wall lengths, ceiling and wall heights
(including soffits or bulkheads)

All window and door sizes and exact locatic

Any floor or ceiling obstacles that interfere with the design

Appliance, sink sizes and flooring footprint locations if applicable

All plumbing, electrical and/or gas are in the correct location on this design OR that they can be relocated.



OVEN CABINETS are standard configured for a single oven and are designed to be field-modified to accommodate a double oven configuration.

This includes removing the drawers, depending on the cut-out size required.

Please refer to your appliance's installation specifications for cutout requirements.

Please refer to our [Specification Guide](#) for maximum and minimum allowable cutout dimensions.



A CORNER SINK configuration consists of a 17" face frame with door attached, and a 36" corner floor bottom.

No side panels or backing are included for this assembly. Maximum sink width is 25 3/4". Floor support and toe kick must be field constructed.



GLASS DOOR CABINETS include clear glass. This is shipped separately for your cabinet order and must be installed on the job site. The interior of the cabinet is finished to match the face frame of the cabinet. The cabinet door is prepped for glass should you choose to purchase your own glass



CABINETRY SIDES are pre finished to match the color of the face frame.

Optional decorative panels are available in select sizes. Please let your designer know if you are looking to view this option.

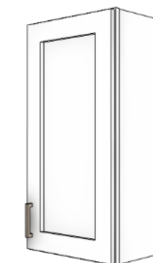

NOTE TO CUSTOMER: Please review all design notes. Contact your personal designer with any changes to your layout at designservices@hdckitchens.com.

DOUBLE-CHECKING MEASUREMENTS

Only you can provide us with accurate measurements, so it is best to measure twice and order once!

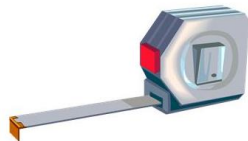

For your convenience we have developed a [How To Measure Guide](#) to help you verify and record your measurements correctly.

We have also produced a short video on [How To Measure](#) to help with your accuracy.

INSTALLATION PLANNING

Do not remove your existing cabinetry until all new cabinetry has arrived complete and has been inspected for shipping damage. (Please review the notes on [Receiving Your Order](#))

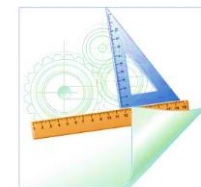

For your convenience, here is a link to our [Installation Guide](#).

This will help to identify the tools needed for your install, so your project can be completed in a safe, secure and timely manner.

CHARACTERISTICS OF WOOD AND FINISHES

To be sure you have the correct expectation of your door style color, finish and species we can provide you with a guide detailing the Natural Beauty of Wood; just ask your designer.



We offer more than just wood doors! We also offer a thermofoil door style that is 3/4" MDF sealed with a durable vinyl laminate, and designer painted door styles that are 3/4" MDF with a durable painted finish.

CARE AND MAINTENANCE

To help keep your cabinets as beautiful as the day you received them, and functioning as well as the day they were built, they will require some minimal care.



We can provide a Care and Maintenance Guide to help you enjoy your investment for a lifetime; just ask your designer.

NOTE TO CUSTOMER: Please review all design notes. Contact your personal designer with any changes to your layout at designservices@hdckitchens.com.

DELIVERY INFORMATION

Home Decorators Cabinetry orders are shipped prepaid to your location with **in-home delivery service**.



Deliveries are made only to the address specified on your order. **Orders are delivered to the first available secure dry area of your home; drivers are not responsible for moving the cabinetry to their final location, or disposal of packaging materials.**

All shipments are valid for one customer, to one location in the continental United States and cannot be separated into multiple deliveries to multiple locations. Deliveries are made only to a home or job site.

All shipments are palletized and shrink-wrapped.

A delivery agent will call to make a delivery appointment (Monday-Friday 8:00 AM EST-5:00 PM EST) within a four-hour window you specify.

Shipping and handling charges cover one delivery attempt to you. In the event that, due to your availability or circumstances, an order is not deliverable you will be responsible for any additional shipping and handling charges.

If you have additional shipping requirements, please call our customer service specialists at 866-676-9131, or email us at customerservice@hdckitchens.com.

RECEIVING YOUR ORDER

Deliveries are made only to the address specified on your order. This is an opportunity for you to check your delivery against the Bill Of Lading, and inspect the packages for any visible shipping damage.



Please remember to receive, inspect, and sign for all deliveries.

If the item(s) that you purchased have become damaged during shipping, **please document the damages with the freight company upon delivery**. Notify us immediately by calling 866-676-9131, or emailing us at customerservice@hdckitchens.com. **All freight damage must be reported within 14 days.**

All items should be checked against the Bill Of Lading and packing slip supplied by the driver for each delivery.

The Bill Of Lading indicates the number of cartons in the delivery, but does not represent the number of pieces. Some items may be boxed together such as molding, hardware, etc.

Cartons containing multiple items will have separate labels on the carton for each item included, and will correspond to the packing slip.

If you have additional questions on receiving your order, please call our customer service specialists at 866-676-9131, or email us at customerservice@hdckitchens.com.

NOTE TO CUSTOMER: Please review all design notes. Contact your personal designer with any changes to your layout at designservices@hdckitchens.com.