

TheRTAStore.com Room Design

Designed For: Natalia Price

Designed By: Lauren Thompson

Finish Name: Linen Shaker Ready to Assemble

Designer Phone: 845-779-2039

Office Phone: 877-992-2246

Designer Email: lauren@thertastore.com

Date: 06/26/2023



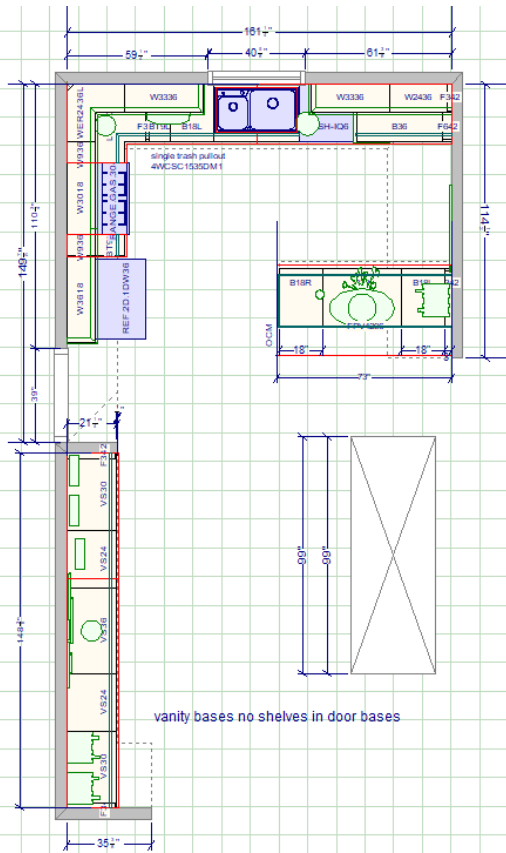

BUDGET LINDR SRK
 Natalia Price
 treehomemanchester@gmail.com

LINEN SHAKER
 READY TO ASSEMBLE
 Ceiling Height: 92 1/2"
 Cabinet Height: 90"
 Wall Height: 36"

Top Molding: FILLER F398- cut to fit on site by customer (3)
 Toe Kick: TK8 (5)
 Base Molding - peninsula back and sides (2)
 touch up kit.

Range: 30"
 Refrigerator: 33"
 Hood: 30"
 DW: 24"
 Sink: NOT CONFIRMED - CUSTOMER TO PURCHASE TO FIT INSIDE 36" BASE

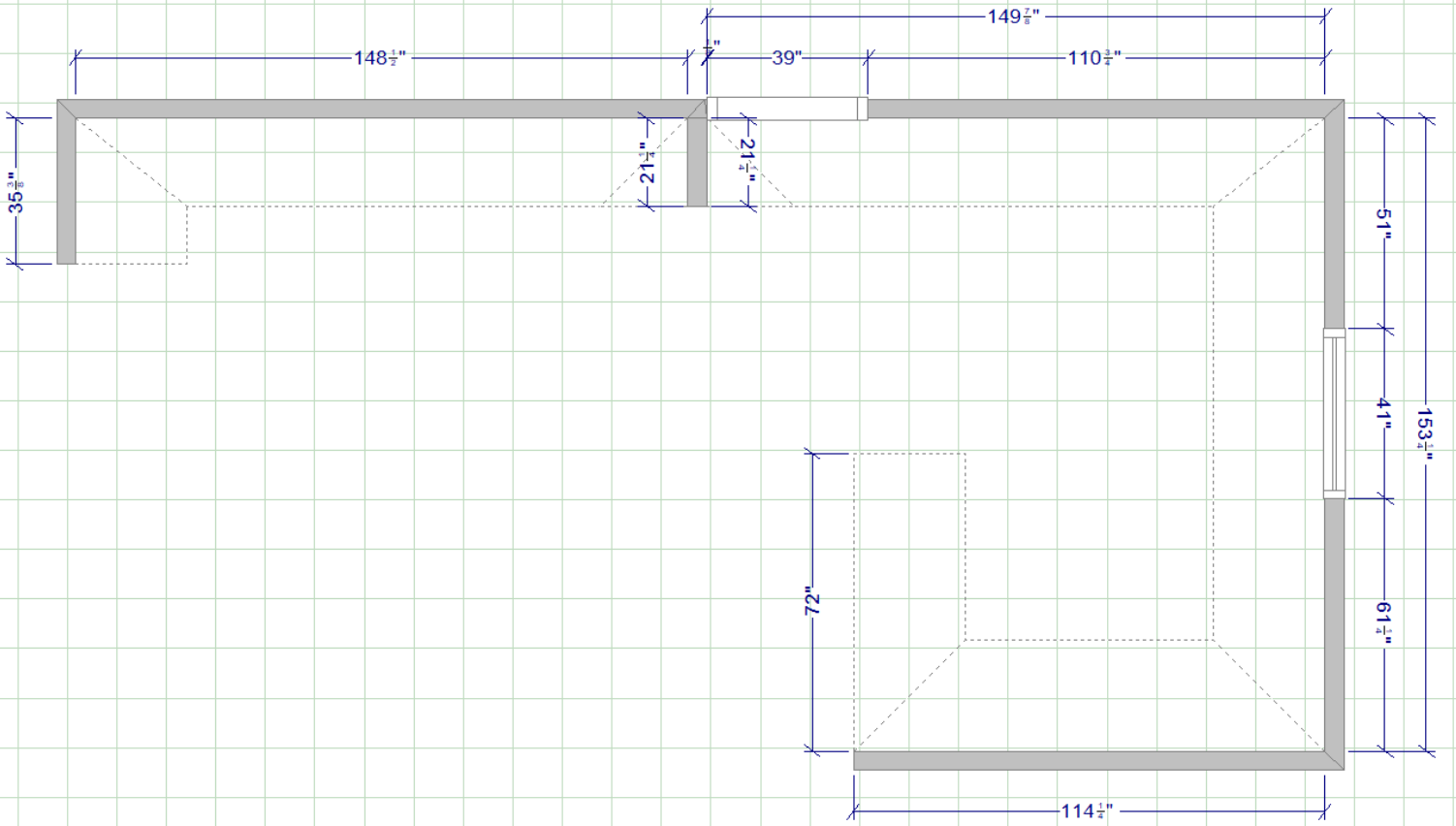

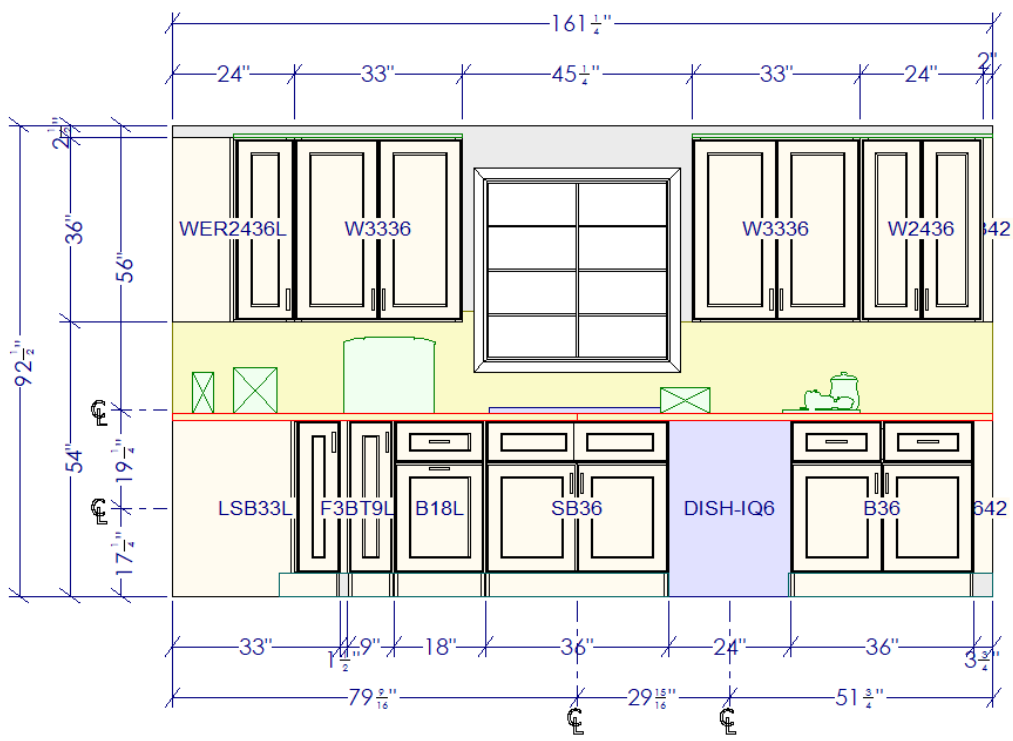

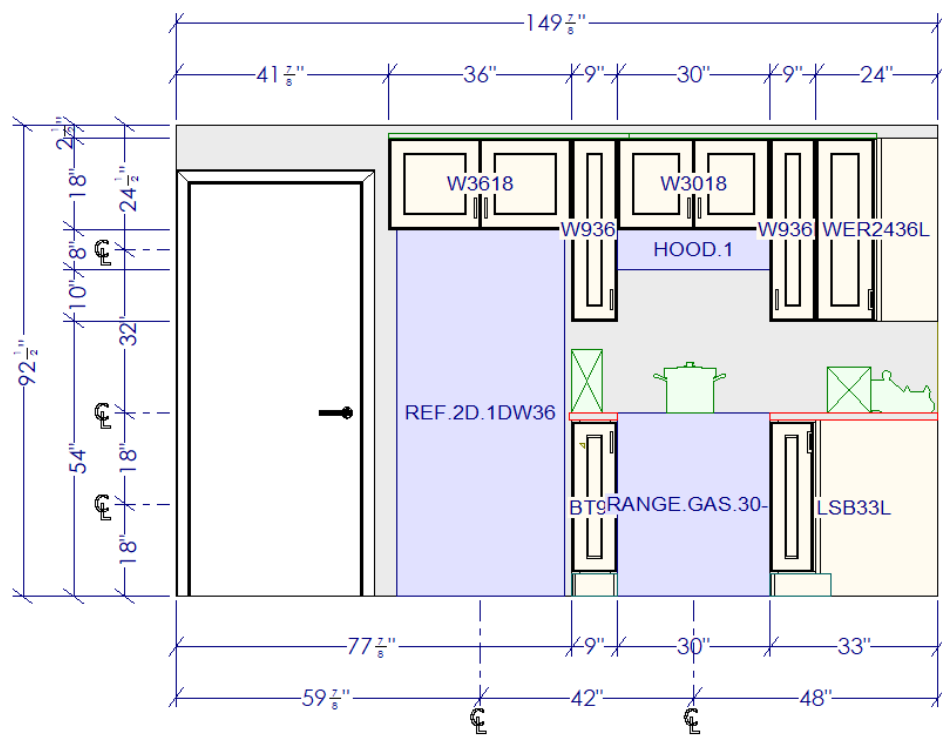

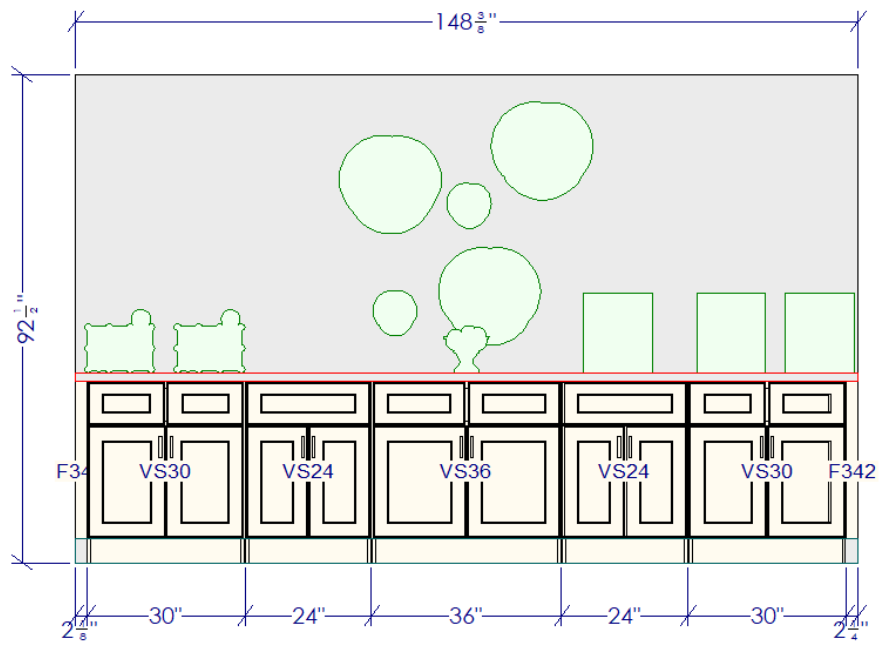

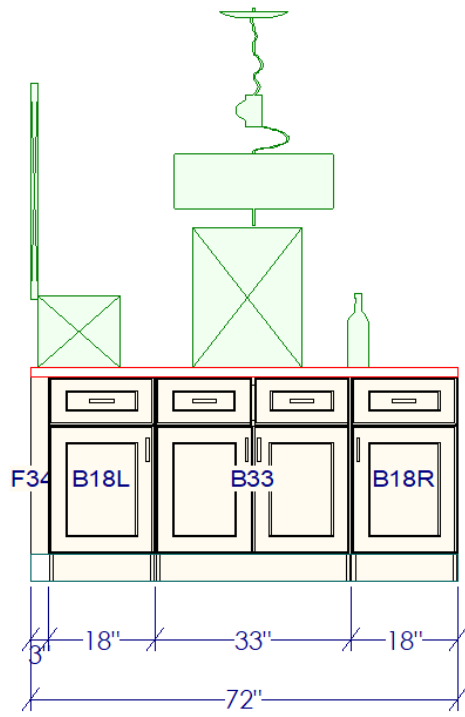









The Importance of Trims & Moldings

Trims and moldings are an important part of your kitchen design as they provide a finished and polished look to your cabinetry. There are a wide variety of moldings and uses for each type. Below is a brief description of the common types of moldings used in designs.

- **Fillers:** Fillers can be used in a variety of ways but the most common purpose it holds is to fill gaps between walls and cabinets. They are also used as a way to space doors and drawers from walls, appliances, or any other obstruction that would inhibit the cabinets' doors or drawers from fully opening. Fillers are sold in 3" and 6" widths and a couple different height options. Fillers can be used horizontally or vertically and do need to be cut on site to fit the specific size you're needing to fill.

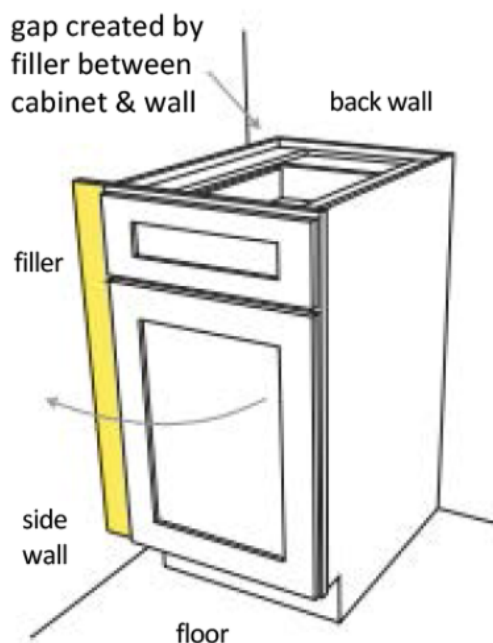

- **Crown Molding:** Crown molding is a decorative molding that is installed on the top of wall cabinets. There are several different types and sizes of crown molding. All of these moldings come in an 8-foot length and need to be cut on site to fit your wall cabinet runs and angles.
- **Light Rail Molding:** Light rail molding is a decorative molding that is applied to the bottom of wall cabinets. It is typically installed to hide under cabinet lighting but can also be an additional decorative feature that pairs nicely with crown molding. The light rail molding comes in an 8-foot strip that needs to be cut on site to fit your wall cabinet runs and angles.
- **Base Board Molding:** Baseboard molding is a decorative molding that is applied to the bottom of base cabinets and is typically seen on the perimeter of islands and peninsulas. This is used in place of toe kick and will come in an 8-foot strip that will be cut on site to fit your base cabinet runs and angles.
- **Stacked moldings:** Stacked crown molding is a popular feature for customers who want their crown molding to reach the ceiling or just to add a bold and taller molding to the top of wall cabinets. Stacked moldings are achieved by placing a horizontal tall filler on top of the cabinets and then overlapping crown molding on top of that. It is recommended to use scribe molding to help transition these pieces. Checking your ceiling height and height of wall cabinets is important to ensure you have enough space to add this to your layout. All moldings are cut on site and come in 8-foot strips.
- **Outside Corner Molding:** Outside corner molding is a molding used to finish raw corners and edges. Typically, this molding is used on the corners of an island where the back panel meets the side panel. The outside corner molding is placed vertically and gives the island a more complete and polished look. This molding comes in 8-foot strips and needs to be field cut.

The Importance of Trims & Moldings Continued

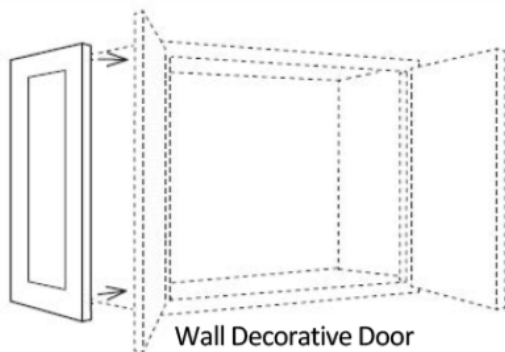
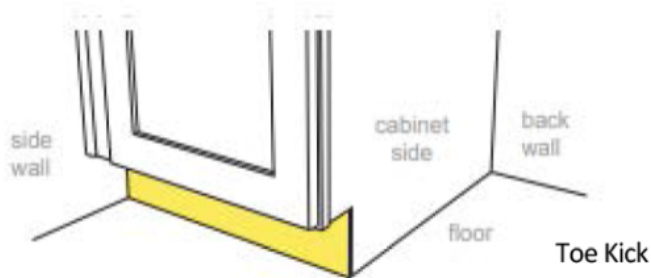
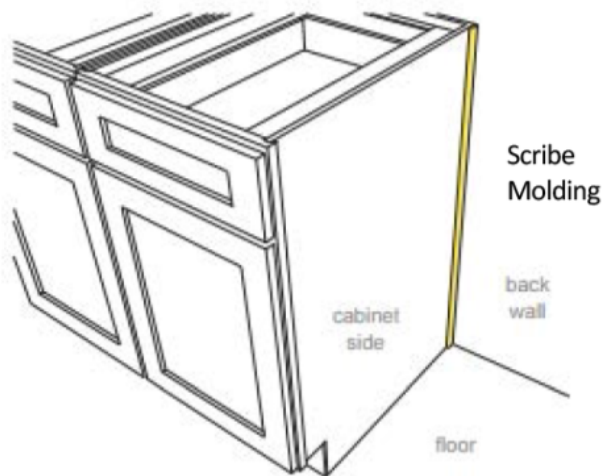

- **Scribe Molding:** Scribe molding is used along the wall or ceiling when cabinets/fillers meet a non-plumb wall to hide gaps. Scribe molding can also be used on the ends of toe kick, moldings, or open spaces to cover raw or cut edges. This molding can be placed horizontally or vertically and comes in an 8-foot strip which would be cut down to size on site. The standard width for scribe is 3/4-inch. It has a straight edge on one side, which is usually placed flush against the wall. The other, bottom side curves to meet the cabinet.
- **Toe Kick:** Toe kick is used as a panel to cover up the gapping created by the placement of cabinets. It is applied to the recessed area where the cabinet meets the floor. Toe kick does come with certain finishes but it is cut to size for each cabinet. There will be seams when the cabinet butts together so it is important to include additional toe kick to place in front to cover the seams. Toe kick is sold in 8-foot strips and is cut on site to fit your installed run of cabinetry.
- **Decorative Doors:** Decorative doors are applied to the sides of the wall, base, and tall cabinetry. The decorative doors will match the door style you have selected and dresses up the exposed sides of your cabinetry. Decorative doors do require the use of shims during installation and is installed onto the face frame (not behind, where the side recesses in 1/4"). The shims will be used to level the door from the back of the cabinet.

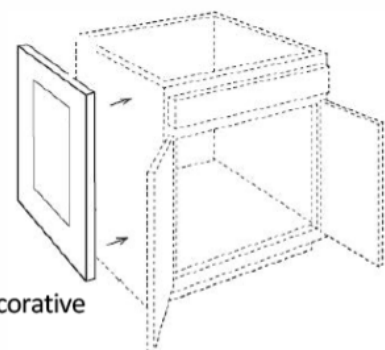

Creating the Perfect Look

Creating the perfect look can sometimes require additional steps when installing your cabinetry. Below is a list of common modifications made on site for popular features found in layouts. If these are added to your design you may need extra trims/moldings that your designer can help add to your cart.

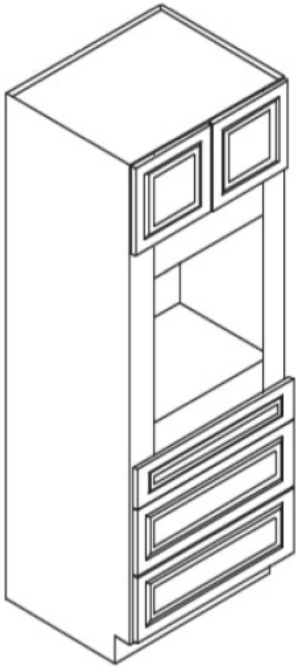

- **Oven Cabinet:** Most of our cabinetry collections carry a universal oven cabinet which needs to be modified on site to fit a single oven, microwave/oven combination, double oven, and warming tray. The cabinets need to be field modified to fit your specific appliance measurements. Please refer to your appliance's installation guide for cutout requirements. Your designer will be able to assist in making sure your appliance fits in the oven cabinet that your cabinet collection offers. Sometimes additional fillers, panels, and scribe molding are recommended to help your appliance fit better into the oven cabinet.
- **12" Deep Base Cabinets:** A lot of layouts require the use of 12" depth base cabinets. An easy way to achieve this is to use wall cabinets as the base cabinet but it does require a simple on-site modification. The toe kick needs to be built on site so you do need to purchase plywood locally and build a 4.5" plywood platform which is then covered with the toe kick material or baseboard molding that we can supply. If the back area is exposed you would also need to purchase the finished back panel and outside corner molding to finish the look!

- **Farm Sink Base:** Some of our cabinetry collections offer a pre-made farm sink base; however, if it does not then there are a couple simple steps used to achieve the same look! Your designer can help make sure you have everything you need for your specific farm sink.

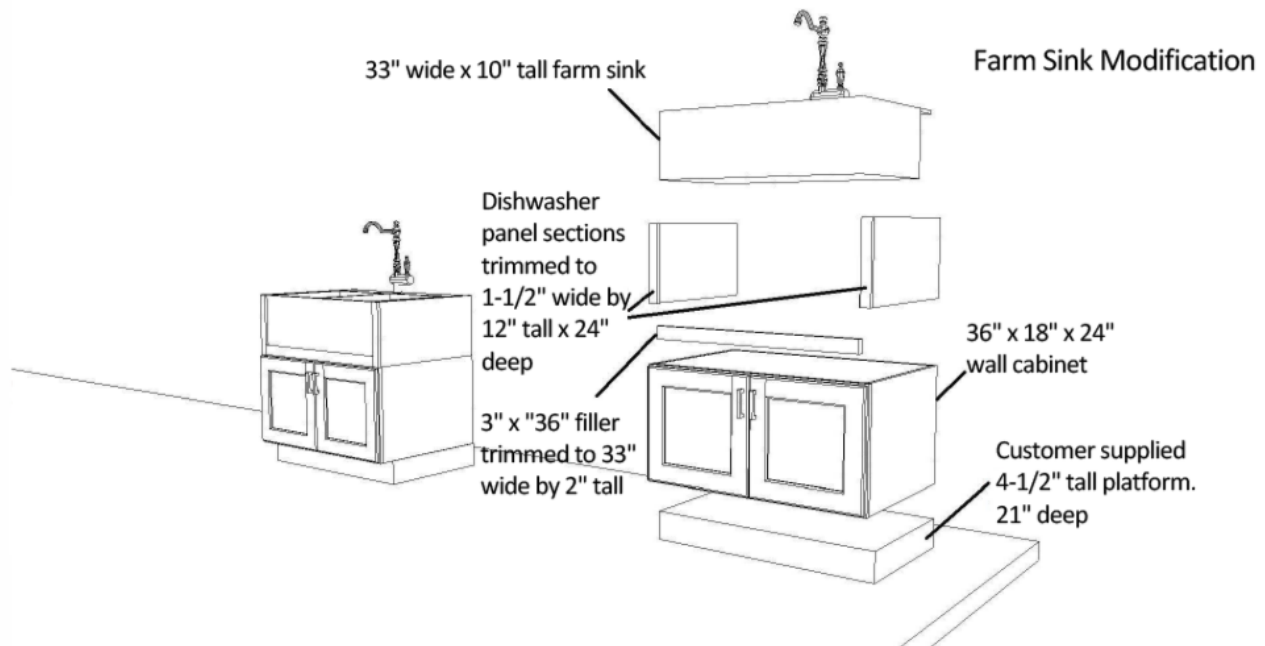

Disclaimers

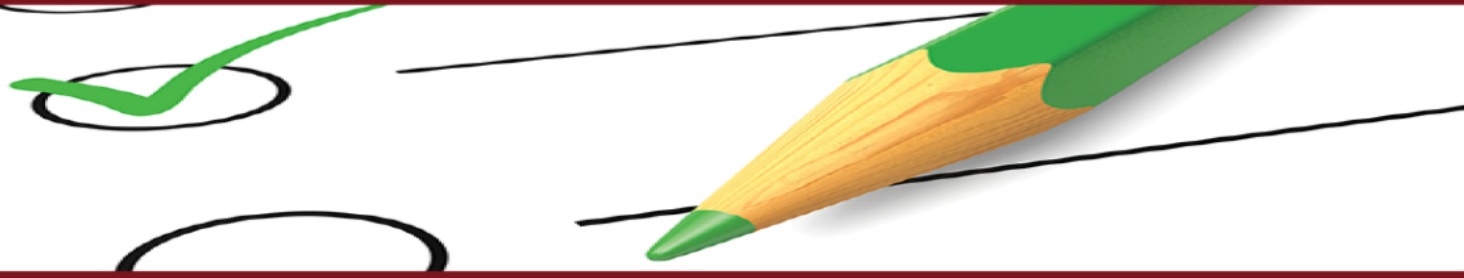

Please verify all items below before placing your order:

- All wall lengths and ceiling heights (including soffits or bulkheads)
- All windows and door sizes and exact locations
- Appliance, sink sizes and flooring footprint locations and sizes if applicable
- All plumbing, electrical and/or gas are in the correct location or that they can be relocated

Please note, if you have a cabinet that is the same height as your ceiling (pantry, oven cabinet, etc) you will need to assemble and install it standing up. If your cabinet is pre-assembled you will need to cut the toe kick or modify the cabinet on site. The cabinet will hit the ceiling if you try to stand it up at an angle in the room.

Please be sure to double check the finish you are ordering is correct and that you have specified ready to assemble or pre-assembled. If pre-assembled was selected you will need to include hinging options.

If changes are made to your order that does not match the design that was done by your designer they will be contacting you before the order is released to verify it is correct and that no changes are needed.

When going to checkout, please use the same email address your shopping cart has been built in. Otherwise your order may not be able to be double checked before being placed with the manufacturer.



Door Sample Recommendation

We highly recommend ordering door samples before purchasing any cabinets to make sure the finish and style are exactly what you want. It is very difficult to see a true finish/paint digitally or with a written description. If you choose to order cabinets without seeing a sample first and do not like the cabinets once delivered, you will be responsible for the normal restocking and return policies as outlined here: <http://www.thertastore.com/rta-faq>. Remember that door samples are completely refundable if you return them when you're finished (you're only responsible for the return shipping) so feel free to order as many as you'd like!



Helpful Information About Your Order

Lead Times

We work with several different manufacturers. The time it takes to process, pull the items and get them situated on a pallet varies per manufacturer. Generally orders are ready in 5 to 15 business days. There are some assembled cabinet collections that have a lead time of up to 4 to 8 weeks. These collections are the Roosevelt, Legacy, Manchester Shaker, Society Shaker, Highland & Kingsport and they are painted/stained on site and then built. Please check the website for a more specific lead time.

Purchasing multiple finishes/accessories will lead to multiple shipments

As mentioned we work with multiple manufacturers. Any time your order has different finishes, hardware, sinks or inside cabinet accessories, these items will ship from different locations. Typically the accessories will ship via UPS Ground or FedEx Ground. However, if you ordered two finishes with 6 or more cabinets in each of the finishes you will receive multiple freight deliveries.

Stock is constantly changing

We are notified at the time we place your order with the manufacturer if any items are out of stock. We will then contact you to make a decision based on when the item is due back in. Delayed responses can result in the loss of more inventory so please be sure to check your email frequently. When we are aware of a finish having many items delayed, we will note this on the site. It can be found under the specific finish's lead time.



Freight Deliveries

We hire independent freight carriers to get your cabinets delivered from the manufacturer's location to you. Freight deliveries are typically made by 53' tractor trailers. Most freight carriers are "No Touch". This means when they come to the warehouse to pick up your order, we load the pallets onto their trailers. When the truck arrives at your driveway for your delivery, it is the responsibility of the person receiving the delivery to take the freight from the back of the truck. The driver will move the pallet to the back of the truck. If the pallet can safely fit on the Lift Gate, the driver will put it on the Lift Gate and lower it to the ground.

Lift Gate is NOT Always an Option

Our manufacturers build pallets as they deem fit to ensure minimal to no damage during transit. When purchasing items that have an overall length or height of 96", Lift Gate is not an option. Pallets larger than this size are used to make sure the items are situated within the pallet. Any pallet over 96" will not fit on a lift gate. It is always best to have a couple people on hand at delivery helping you move the boxes. Some boxes can be very heavy and awkward for one person to move.

Delivery delays happen

Orders ship with freight carriers and mishaps can happen. Due to the cabinets traveling by way of road, many variables can affect the delivery process. Delivery times are not guaranteed. Please keep in mind that delivery time frames and/or days may need to be rescheduled on occasion.

What to Expect After Placing Your Order

Day 1:

We typically process orders within 24 hours. However, during sales the volume of orders can delay this slightly. If any changes need to be made, please make sure to notify us within 24 hours of when you placed your order, otherwise changes may not be possible.

Days 2 to 4:

Next we will send you an email letting you know we are processing your order and it will be ready to ship in "x" business days. This email will come from one of our team members so please be sure to add all "@thertastore.com" email addresses to your email provider's safe sender list.

In this same time period you may be contacted by email from a team member to let you know if any items are out of stock. This email will give you options so you can decide how to proceed with your order.

Days 3 to 15 (can be longer if you ordered assembled cabinets):

Your next email will be to let you know what items on your order have shipped, in addition to the name of the freight company and the tracking number.

Most orders will ship with freight carriers unless the order is small and not assembled. If this is the case, the item(s) will ship with UPS Ground or FedEx Ground. These small shipments will be delivered to your door and will not need to be signed for. Keep in mind that if you order any accessories outside of the cabinet finish, these will ship separate from your cabinet order. These typically will be delivered via UPS Ground or FedEx Ground.

Orders that will be delivered by a freight carrier will have the carrier's information in that shipping email such as R & L Carriers, and A Duie Pyle. The day you receive this email, a team member will call the number you listed on the shipping address. This phone call is to let you know your order shipped and that we have sent you an email with very important information to review. Please be sure to check your email for this information.

Days to follow:

Once your order ships, the freight carrier will be the one to contact you to setup your delivery appointment. It is best to communicate any questions you have regarding the delivery day and time with them. If you are unsuccessful with the carrier, please contact us to help you out!



What To Expect On Your Delivery

When your order ships you will receive a phone call & notification email from a team member at TheRTAStore.com, which outlines what to expect at the time of delivery and how to receive your order. It is extremely important to review this email as it will contain specific information about your shipment such as the carrier & tracking number, as well as the pallet and box count for your order.

We hope there aren't any issues with your order, but if there are, know that our claims team will be there to help resolve it for you in the quickest and smoothest way possible.

A few things to know:

- Freight shipments will be curbside, end of truck deliveries. If a lift gate can be used for your shipment, the driver will lower the pallet to the ground. We recommend having 2-3 people there to help you move the boxes.
- Take a photo of the pallet on the truck showing what your shipment looked like at the time of delivery.
- The driver will have you sign for receiving the shipment. Do not sign off until you have done a visual inspection of the exterior of the boxes, pallet, and shrink wrap for any signs of damage and a piece count. Your piece count should match the information sent to you in the shipment notification email. If there are any damaged or missing items, this must be documented on the signed delivery receipt.
- Please do not refuse any items, as this will delay the replacement process.
- After the driver leaves, you have 5 days to open and inspect the shipment for any concealed damage (damage not noted at the time of delivery) and report it to the carrier and to TheRTAStore.com. Please do not file any claim paperwork with the carrier - we will handle this for you.
- In order to get the ball rolling with your replacements, we will need a list of the items/parts requiring replacement and photos of the issues.
- If you have any questions or concerns, feel free to reach out anytime via phone, email, or chat!



Why You Can Trust Us!

TheRTAStore.com was built off the need for top quality customer service and affordable cabinetry for every room in your home! We have broken down the barrier between the two and they are no longer mutually exclusive 😊

Purchasing cabinets can be a daunting task - especially online. We like to take out the scary aspect of purchasing online and turn it into a fun project that will not only make your room look great but will undoubtedly increase the value of your home as well! Our professional designers can help you every step of the way! From initial ideas, to measuring, to design, tweak, and completion - until you are completely satisfied!

But what about purchasing such a large amount online?

That's a great question – why should you trust us? Here is why:



- **Safety:** We are both McAfee and Norton Secure with a 128-bit (SSL) encryption
- **Service:** We have an A+ rating from the Better Business Bureau (BBB), a 5 star rating from Trustlink.org, and an excellent rating from ResellerRatings.com!
- **Leadership:** We are leaders in what we do! We have been honored on Internet Retailers Second 500 List every year, since 2011! We have also been featured in the Inc. 5000 list of America's Fastest-Growing Private Companies since 2015!
- **Featured Products:** Our products have been featured on numerous HGTV and the DIY Network television shows! Our cabinetry has been featured on the DIY Network's Blog Cabin 2 years in a row!
- **Incredible Reviews:** Check out our amazing customer testimonials if you need more proof!
- **Proud member of the National Kitchen & Bath Association since 2009!**

Tips For Keeping Your New Kitchen Cabinets Looking Beautiful!

Dryer is Better - Keep cabinet surfaces dry and at a consistent temperature – drastic/quick temperature changes and excessive moisture can be harmful to the finish/paint and overall cabinet stability.

Dust Removal - For dust removal, simply use a soft, lint-free cotton cloth to wipe down the cabinet surfaces.

Basic Cleaning - For a basic cleaning, use a soft, lint-free cotton cloth dampened with a mild detergent or soap (make sure it's ok for use on wood products), and warm water, then dry surfaces immediately. Never leave a cloth moistened with cleaners on a cabinet surface for any length of time.

Blot don't wipe - For better results, use a blotting action instead of a wiping motion when cleaning.

Don't Be Harsh! – Avoid using a dish cloth or sponge since harsh detergent residues may harm finishes/paints. Stay away from ammonia-based cleaners and soaps with dye and never use scouring pads, steel wool, wire brushes or powdered cleaners. Don't allow oven cleaner to touch any part of the cabinet. Avoid sliding objects across the cabinet surface and be careful with knives and other sharp objects that can damage the cabinets.

If In Doubt, Don't Use It – If you're not sure of a cleaner's suitability, don't use it.

Wipe Spills Quickly – Food spills and grease will come off more easily if they are removed quickly. Wipe up spills and water spots immediately with a lint-free cotton cloth so moisture is not absorbed into the cabinetry.

Watch Out For Print – Don't leave printed materials

(newspapers, magazines, etc...) on the cabinet surface. The printing ink can bleed into the cabinet finish.

Avoid Moisture & Heat – Don't drape wet or damp dish towels over doors of base cabinets, attach towel racks to the interior of cabinet doors and be sure to use trays under potted plants to catch excess water. Try not to place small kitchen appliances where the heat or steam is directed onto cabinet surfaces and always protect wood surfaces by using trivets/pads under hot items.

Glass Care – Use a household glass cleaner with a soft, clean cloth. Spray the cleaner on the cloth rather than the glass itself and try to avoid excess cleaner running into the cabinet joints and grooves.





Talk to Us:

Speak to a live person at: 877-992-2246
Monday-Saturday 9am - 5pm Eastern Time
(Closed Thanksgiving, Christmas, and New Years Day)

Email us at:

kitchendesigns@thertastore.com
24 hours a day, 7 Days a week (Including Holidays!)